



SIWI PARTNER PUBLICATION

Reducing Emissions from Antibiotic Production

*Whitepaper on policies, technologies, and enabling conditions
for sustainable antibiotics manufacturing.*

Copyright © 2020, Stockholm International Water Institute, SIWI

ISBN: 978-91-88495-16-7

How to cite: Schaaf N., Panorel I., Caputo A., Prakash S., Shaw B., Verma N., and Veem K. 2020. Reducing Emissions from Antibiotics Production, SIWI.

Cover photo: iStock

Editor: Nicolai Schaaf

Graphic design: Helena Öhman, Studio Indigo

Printing by Molind AB

This project was funded by the Swedish Postcode Foundation

For electronic versions of this and other SIWI Swedish Water House publications, visit www.siwi.org/publications

Contents

Summary	5
1. AMR and the environment	7
2. Antibiotic Manufacturing and AMR	7
Antibiotic Manufacturing in India	8
3. AMR strategies and the growing demand for sustainably produced antibiotics	8
Industry Initiatives	8
National and international initiatives	9
Sustainable Public Procurement of Pharmaceuticals	9
4. National AMR Policies in India	10
National Action Plan	10
The Kerala Antimicrobial Resistance Strategic Action Plan	11
Madhya Pradesh – second state to have plan for antimicrobial resistance	11
Other AMR Programs in India	11
5. Shared objectives to achieve sustainably produced antibiotics	12
6. Technologies to reduce antibiotic emissions into the environment	14
Wastewater sources and flows in an antibiotic pharmaceutical manufacturing plan	14
Process Improvements for reducing antibiotic pollution in pharmaceutical effluent	14
Treatment technologies used for treatment of pharmaceutical wastewater	15
7. Monitoring Tools to Measure Antibiotic Pollution in Treated Wastewater & Water Sample	18
8. Lack of Standardized Methods and Regulations for Monitoring Antimicrobial Manufacturing Wastes	18
Need for Complementary Bioanalytical and Molecular Assays to Assess Impacts of Manufacturing Wastes	20
Conclusions	21
Recommendations	23
References	25



Photo: Nicolai Schaaf

Acronyms and Abbreviations

AMR	Antimicrobial Resistance
API	Active Pharmaceutical Ingredient
ARG	Antimicrobial Resistance Gene
(C)ETP	(Central) Effluent Treatment Plants
LC-MS	Liquid Chromatography coupled with Mass Spectrometry
MIC	Minimum Inhibitory Concentration
NAP	National Action Plan
NGO	Non-Governmental Organizations
PNEC	Predicted No Effect Concentration
REAP	Reducing Emission from Antibiotics Production
ZLD	Zero Liquid Discharge

Summary

The rise of antimicrobial resistance (AMR) is undermining the effectiveness of antibiotic drugs in the treatment of common infections in humans and animals. Drug resistance has been spreading over time as a result of the irrational use of antibiotics in human and veterinary medicine, animal production (e.g. growth promotion) and discharge of untreated or insufficiently treated waste and wastewater from a variety of sources. Numerous studies and reports have highlighted the contribution of solid and liquid waste from manufacturing reaching the environment and leading to high concentrations in recipient waterbodies that can trigger AMR.

The international community is working towards reducing the irrational use of antibiotics in humans and animals; however, the initiatives to reduce the potential health and environmental impact of AMR related emissions from pharmaceutical manufacturing appear fragmented and lack recognized standards between suppliers, buyers and regulators that could guide a consensus of what sustainable manufacturing of antibiotics should look like and how it can be achieved. Beyond that, antibiotic pollution continues to attract significant international media attention, with the potential to significantly damage the reputation of pharmaceutical companies as well as key exporting nations like India. At the same time, mounting global pressure to promote sustainable production and consumption of goods and services generally is leading to changes in global procurement practices and environmental regulations for antibiotics.

This whitepaper summarizes the findings of the project Reducing Emissions from Antibiotics (REAP), that SIWI has run in partnership with UNDP, funded by the Swedish Postcode Foundation. It analyses AMR policies and strategies and practical solutions to address emissions of antibiotics from manufacturing sites as well as the enabling factors required to implement the solutions. While the solutions should be globally applicable, the focus is on practices, challenges and regulations in India, with India being one of the key global suppliers of antibiotics and several regulative and industry initiatives already addressing these factors. Highlighting the shared objectives of selected strategies, initiatives or regulations is at the core of the analysis, leading to the working definition that **sustainable antibiotics manufacturing reduces the release of antibiotics to the environment to levels that, according to best available knowledge, do not trigger antimicrobial resistance. To avoid trade-offs with resource and energy costs, this should be achieved in a cost and resource efficient way and supported by corresponding market demands.**

In other words: To prevent the manufacturing process of antibiotics to contribute to this risk, the APIs need to be retained in the production facility or deactivated before liquid or solid waste streams can enter

the environment. Acknowledging this bottom line as shared objectives in a broad stakeholder dialogue has been the main outcome of the project REAP. There are technical solutions available to ensure the necessary waste treatment. And there is a growing interest from regulators and procurers to demand, and also incentivize such improvements.

The challenges are on the one hand to find the context specific best technology and to minimize trade-offs with resource and energy consumption for implementing these. Holistic, resource centred approaches should address the whole manufacturing process rather than only the waste and effluent streams. On the other hand, access to verified information about real improvements made is a precondition to motivate potential incentives. The missing link between these ends is the lack of globally established standards for safe environmental concentrations and the monitoring capacity to trace both antibiotics and resistance genes in the environment.

The expected regulation of discharge limits in India and the common antibiotics manufacturing framework as proposed by the AMR Industry Alliance, matched by the sustainability criteria for public procurement emerging in several countries, provide a good starting point to address these challenges. But more experience in implementation, sharing of best practice and an improved mutual understanding of the requirements and possibilities of the supply and demand side of the market are preconditions to enable scaling and standardization of these initial steps. Otherwise, the risk of mismatching approaches inside separate silos will prevent market and regulation from providing the necessary balance between incentivizing the pioneers and penalizing practices that contribute to AMR as a global health risk.

But understanding these complexities and seeing the possible solutions only helps to a certain extent. Law enforcement and stringent application of politically set targets in the day to day business is often a challenge. The key enabling factor will be to bring the pioneers together who actually want to change the situation. The current initiatives within the UN and a few countries on the demand side, and voluntary industry initiatives like the AMR Industry Alliance are the starting point where such an alliance can be built. Operationalizing the commitments that are already there and scaling them to standards for the sector is a huge challenge that requires spearhead initiatives and multi stakeholder support, including investments, training and – most of all – collaboration.

The key recommendations are applicable on the national level in India as well as in scaling these experiences to other countries and internationally:

1. **National and state level AMR strategies and action plans should address antibiotic discharge into the environment from manufacturing;**
2. **Policy coherence is required between the ministries of environment, health and industries;**
3. **Regulation should limit antibiotic discharge into the environment;**
4. **Public procurement should promote sustainable manufacturing;**
5. **Suppliers should contribute to transparency and the collaborative promotion of solutions;**
6. **Multiple funding sources and incentive systems are needed to achieve large scale improvements;**
7. **Effective monitoring systems are needed as the baseline for compliance control;**
8. **Effective enforcement requires acceptance, training and capacity building;**
9. **Transparency and confidentiality may be conflicting interests that have to be addressed;**
10. **Standardization and sharing of best practices should contribute to coherent implementation and replication of solutions.**

To enable this, a **public-private partnership**, is proposed to address the given complexity of manufacturing, local and global impacts, market and regulation in a collaborative and transparent way. While the suggested holistic and multi stakeholder approach, based on the shared objectives, should be a no-regret option for all sides, reality shows that health, environment and profitability objectives can still generate trade-offs. To prevent and solve these, a **long term global collaboration platform** is suggested to provide the space for building trust and mutual learning and as a precondition for coherent and sustainable implementation of solutions on the required global scale.

1. AMR and the environment

When microorganisms are exposed to antimicrobial substances for a significant time, resistance genes can be triggered. This can occur in the natural environment, wastewater streams, healthcare facilities, aquaculture ponds or cattle farms. Furthermore, hotspots characterized by high levels of antimicrobials increases the probability that microorganisms will develop resistance. Gene transfer further increases the chances of pathogens to develop resistance. The resistance of pathogens to antibiotics, antivirals, antifungals, anti-malaria agents etc is defined as Antimicrobial Resistance (AMR) – often used synonymously with the resistance of bacteria against antibiotics. While AMR in itself is a natural phenomenon, the increase in use and overuse of antibiotics in human and animal health, has accelerated the development of AMR and the spread of bacteria carrying resistance genes.

Today, we are facing resistance preventing successful treatment of TB, Malaria and HIV/AIDS and many others. The WHO estimates that there are more than 500,000 new cases of multidrug resistant TB every year.¹ The rise of AMR poses major economic and health burdens on society with diseases leading to increased healthcare costs, loss of productivity, incomes and ultimately lives. According to United Kingdom's Review on Antimicrobial Resistance² of 2016, by 2050 AMR could claim 10 million lives per year with an economic impact of USD 100 trillion.

In low- and middle-income countries, the situation is often exacerbated by insufficient sanitation, infection control, food handling, and in some places discharge from the pharmaceutical industry. Untreated sewage is discharged into water bodies spreading antibiotic residues and resistant organisms. Consequently, soils and the aquatic environment become reservoirs for antibiotics as well as vectors for resistance genes (ARGs).³ In addition to being the major pathway of AMR spreading to humans and animals via drinking water, water represents the most influential reactor of ARGs into the environment. Water allows non-resistant bacteria to serve as carriers for resistance genes, exponentially increasing the dissemination of AMR (i.e. going from being harmless environmental bacteria to pathogens), and disrupting the ecosystem.^{4,5} Examples of severely impacted ecosystems span between tiny organisms such as Cyanobacteria, and both wild and aquaculture species of fish.^{6,7} In sum, the combination of irrational disposal of broad-spectrum antibiotics combined with insufficient wastewater management leads to an unprecedented global spread of AMR. This clearly highlights the urgency of both improving current levels of sanitation and the importance of adequate wastewater management – hence the call for regulators to measure and monitor APIs and ARGs in water.

The concentrations where pharmaceuticals do not induce negative effects is called the Predicted No Effect Concentration (PNEC).⁸ Specifically, for antibiotics, there is also a measure of Minimum Inhibitory Concentration (MIC) being the lowest concentration that inhibits bacterial growth.⁹ These indicators guide the understanding of risks of certain environmental or effluent concentrations that promote AMR. However, to date there is no existing regulation taking these into account.

A study on AMR by the University of York tested water samples in rivers across 72 countries.¹⁰ The study found antibiotics in two thirds of 711 tested river sites. Most of the highest values were found in Asia and Africa, including the extreme case of metronidazole found in a river in Bangladesh at concentrations 300 times higher than what the AMR Industry Alliance suggested as a safe environmental concentration. The high concentrations were found in vicinity of wastewater treatment facilities, dumping sites as well as antibiotics manufacturing facilities.¹¹

The UK Government's five-year national action plan for tackling AMR (2019-24) states, "there is no question that antibiotics can be found in both final effluents and in rivers downstream of sewage treatment plants".¹² These results are mirrored in a recent overview on pharmaceutical residue, including antibiotics in freshwater that was presented by OECD.¹³ On an international level, the Strategic Approach for International Chemicals Management (SAICM) decided at the 4th International Conference on Chemicals Management (ICCM4) to address environmentally persistent pharmaceutical pollutants as an emerging policy issue.¹⁴ And many other national, regional and global initiatives address the issue of pharmaceuticals and antibiotics in the environment. There is no comprehensive data for India, but the Government has commissioned a major new study of antibiotic pollution in the Ganges river.

2. Antibiotic Manufacturing and AMR

Improving access to antibiotics for those in need is still required, since more people die each year from lack of treatment than from resistant infections. At the same time, the ongoing initiatives to reduce irrational use of antibiotics in humans and animals have to receive sufficient support and attention.

Another driver for AMR is associated with the manufacturing of antibiotics, where reports have highlighted very high concentrations of antibiotics near manufacturing plants, notably in major manufacturing hubs in India.¹⁵ Producing antibiotics involves chemical synthesis or fermentation, utilizing a range of chemicals and solvents. Both

solid and liquid waste streams can contain by-products or active pharmaceutical substances. To limit wastewater and environmental concentrations exceeding risk thresholds like PNEC or MIC, generating solid waste and wastewater should be avoided as far as possible. If it occurs, it needs to undergo treatment at the factory premises or in an effluent treatment plant. To succeed in this pursuit, technology and regulation must go hand in hand. However, the relevant regulation usually refers to bulk indicators (pH, oxygen demand, total solids, nitrogen content, heavy metals etc.) and bioassay test which do not reveal the risks specific to antibiotic waste and AMR. In addition, the market pressure towards lowest possible prices does not incentivize sustainability efforts in the industry. Despite the contradictions, international concern about the health risks imposed by antibiotics entering the environment from production facilities is steadily increasing.

Antibiotic Manufacturing in India

Because of the number of significant drivers of AMR in India (largely uncontrolled use in human and animal health and food supply chains and deficient access to safe water, sanitation and hygiene), the country has one of the highest rates of AMR in the world.¹⁵

India is also the world's largest producer of antibiotics, supplying over 40% of the global market (the second major supplier is China, where many active pharmaceutical ingredients, APIs, are produced). The industry is diverse, with small, medium and large companies engaged in API manufacturing and formulation.

A number of scientific studies conducted by Indian and international experts have found high concentrations of antibiotics in local water bodies surrounding pharmaceutical clusters in the states of Telangana, Gujarat, Karnataka, Maharashtra and Himachal Pradesh.^{15, 16, 17, 18, 19, 20}

These antibiotic manufacturing zones are hot spots for antibiotic pollution in the environment. For example, the state of Telangana hosts one of the largest pharma clusters in India, contributing 40% of total drugs manufactured and formulated in the country. There are currently 800 pharma and biotech manufacturers in Hyderabad with an estimated annual turnover of USD 13 billion.²¹

Although direct causalities are sometimes questioned when detecting high environmental concentrations,²² most of the studies indicate that air, water and soil around pharmaceutical facilities in Hyderabad and comparable locations are significantly contaminated by chemicals and APIs originating from the production of antibiotics.²⁰ This includes extreme cases of discharge levels of ciprofloxacin at 44 Kg per day, enough to treat a city of 44,000 inhabitants, and leading to concentrations 1000 times higher than what is toxic to bacteria.¹⁷

At present, there are no international or national environmental standards that regulate pollution caused by antibiotic manufacturing. On the state level, however, there are several examples of environmental regulation, requiring measures like Zero Liquid Discharge (ZLD). Smaller companies rely on third party service providers like central effluent treatment plants (CETPs) for treatment before discharge or re-use. Some companies also commit to voluntary sustainability schemes. Despite some efforts, the overall picture is that industrial emissions are a source for antibiotics to enter the environment and a driver of AMR. This is unnecessary and avoidable and swift implementation and effectiveness of countermeasures have to be introduced, monitored and verified.

3. AMR strategies and the growing demand for sustainably produced antibiotics

WHO has developed a Global Action Plan on AMR²³ to advise governments on the development of national action plans to prevent and manage AMR. The focus is on strengthening disease surveillance systems, promoting safe and rational use of medicines, preventing and controlling infection. A global report on *Initiatives for Addressing Antimicrobial Resistance in the Environment*²⁴ highlights a number of high-risk areas such as disposal of waste from healthcare facilities and manufacturing, which could be prioritised and addressed on local and global levels to reduce potential risks to human health.

In the Global Action Plan and hence, many National Action Plans, there is little or no mention of limiting effluents from antibiotic manufacturing as a component in the fight against AMR. This is better represented in industry initiatives, procurement strategies and a few regulative initiatives.

Industry Initiatives

In 2016, over 100 companies and industry associations signed the Davos Declaration on AMR at the World Economic Forum, building the foundation of the AMR Industry Alliance and calling for a sustainable and predictable market.²⁵ In September 2017 at the UN High Level Meeting on AMR,²⁶ a smaller group of companies signed the Industry Roadmap for progress on combating antimicrobial resistance that inter alia specifically highlights the reduction of environmental impact from production of antibiotics and establishes a common set of principles for global action.^{27, 28} Based on this, members of the AMR Industry Alliance developed the common antibiotic manufacturing framework.²⁹ The framework provides a methodology and set of minimum requirements needed to conduct a site risk evaluation of controls

in pharmaceutical supply chains. It sets out minimum standards for companies to adhere to environmental compliance and appropriate antibiotic discharge management. The focus is on setting up minimum requirements for water management, solid waste management programs as well as conducting audits of antibiotic manufacturers. The industry has also compiled Predicted No Effect Concentrations (PNECs) to be used in environmental risk assessment of wastewater discharges, for the most common antibiotics used globally.

The AMR Industry Alliance members working with this framework are auditing their own sites and suppliers according to the methodology and recently published a progress report, stating general progress on implementation, but also indicating a timeline of up to 7 years until the supply chain of member companies will be compliant with the framework.³⁰

National and international initiatives

In 2019, the UN Inter Agency Coordination Group on AMR published policy guidelines for the implementation of global and national AMR strategies.³¹ The recommendations include the issues of pharmaceutical wastewater and solid waste management among other areas and call for funding, multi-stakeholder partnerships and private sector participation.

In 2017, the European Commission adopted the new EU One Health Action Plan against AMR.³² The plan supports EU and its Member States to deliver innovative, effective and sustainable responses to AMR. It provides a framework for a more extensive action to reduce the emergence and spread of AMR as well as develop the availability of new and effective antimicrobials in and outside the EU. The key objectives are: (1) making the EU a best practice region, (2) boosting research, development and innovation, and (3) shaping the global agenda. Manufacturing of antibiotics is mentioned as one source of antibiotics entering the environment and knowledge gaps are highlighted but there is no specific guidance on how to address these issues. The Resolution of the European Parliament on the action plan calls for environmental risk assessments and green procurement to address the release of antibiotics to the environment.³³

The UK Government's five-year national action plan for tackling AMR (2019-24) is one of the few NAPs taking manufacturing into account, providing a strong focus on the environment. Among other things, it seeks to work with other countries to ensure "responsible antimicrobial procurement from manufacturers with transparent world class environmental stewardship in their supply chains" and to "collaborate with industry to promote the development of a global environmental stewardship certification system that can distinguish responsible manufacturers of antimicrobials".¹²

Several other studies or reports highlight the relevance of antibiotics in waste streams entering the environment as a potential driver for AMR, including the emissions from antibiotics manufacturing, e.g. the World Bank.³⁴ OECD also suggests environmental criteria for public procurement and good manufacturing practice as mitigation options, including discharge limits and disclosure of discharge from the supply chains as mitigation options.¹³

Fundamental regulation through Good Manufacturing Practice is being addressed by WHO, having started a consultation on "Points to consider for manufacturers and inspectors in the prevention of antimicrobial resistance".³⁵

Finally, a report with high public impact was the AMR Benchmark published by the Access to Medicine Foundation in 2018, investigating pharmaceutical company action against AMR, including the field of responsible manufacturing and how companies ensure that their production does not contribute to AMR.³⁶ The key finding is that while several manufacturers have environmental risk management strategies in place, few set discharge limits, no one discloses discharge data and only one discloses sub-suppliers. This puts the challenge of transparency in the centre of what regulation and incentive structures can or should provide, beyond the question of what physically needs to be achieved. The second edition will be released during World Economic Forum 2020, indicating progress but still large challenges remaining.³⁷

Sustainable Public Procurement of Pharmaceuticals

The UN Sustainable Development Goal Number 12 aims to guarantee sustainable consumption and production methods through the promotion of sustainable public procurement practices. Put simply, sustainable procurement can stimulate companies to incorporate environmental practices into their production, distribution, marketing and final disposal processes across their supply chain³⁸. Several donors and multilateral banks have begun to promote sustainable procurement practices in their aid programs. For example, the World Bank supports 'smart procurement' through a three-dimensional life cycle approach covering economic, environmental and social development.³⁹

The role of public procurement as a political instrument for reducing emissions of pharmaceuticals to the environment has also been investigated in a report by the cluster group on water and pharmaceuticals, hosted at SIWI Swedish Water House 2013–2016, concluding that clear goals and objectives are needed to enable purchasing agencies together with their suppliers to manage the risks in the supply chain.⁴⁰ Although highly regulated, the antibiotics market has failed to deliver a sustainable

“...clear goals and objectives are needed to enable purchasing agencies together with their suppliers to manage the risks in the supply chain”

balance between costs of production, prevention of externalities like environmental impact and AMR, and a willingness to pay beyond the mere focus on the lowest possible price. With respect to stretched public health-care budgets and the lack of access to antibiotics in many parts of the world, the price is a critical challenge. Nevertheless, the AMR challenge will keep growing if the price pressure keeps disincentivising investments in mitigation measures and potentially higher costs of production. The cost of inaction will fall back on society as even higher health costs and death toll. The critical bottleneck is often political coherence between health, environment and industry regulation with diverging interests of cost savings, protecting health, protecting the environment and protecting the competitiveness of the national pharmaceutical industry.

Some of the mentioned reports highlight market incentives and specifically public procurement as a tool for promoting sustainable antibiotics manufacturing. But there are only a few ongoing initiatives to develop and apply sustainability criteria for antibiotics or pharmaceuticals in general. The most visible ones are found in Sweden, Norway and within the United Nations.

The UN launched a Sustainable Procurement in the Health Sector Initiative (SPHS) in 2012, bringing together UNDP, UNEP, UNFPA, UNHCR, UNICEF, UNOPS, WHO, GAVI, Global Fund and UNITAID. Representing a cumulative purchasing power of USD 5 billion, SPHS aims to lower the environmental and social impact of its procurement and act as a driver for change by engaging with suppliers, facilitating awareness raising and capacity building, developing guidance for sustainable procurement and contributing to the introduction of sustainable procurement and production practices.⁴¹ The initiative also runs the Sustainable Health in Procurement Project (SHiPP), aiming to develop universally applicable criteria for sustainable procurement in the health sector and to strengthen the capacity for sustainable production, procurement, supply and disposal of healthcare products in Low- and Middle-Income Countries.⁴²

The most recent national initiative for sustainable procurement practices can be found in Norway, where the Hospital Procurement Trust manages the procurement of pharmaceutical products for all health authorities in the country.⁴³ It has launched a new antibiotic procurement policy in which suppliers that can document good

environmental efforts during the manufacturing process will have an advantage in the selection process, based on the “supplier’s environmental policy, environmental strategy and control system for environmental issues”. Under the new system, “environmentally friendly production will be weighted by 30 percent as allocation criteria”.⁴³

In Sweden, the sustainability criteria have been updated in 2019, after a long consultation process to better reflect the current state of knowledge.⁴⁴ Beyond the availability of basic supply chain information and environmental risk information of the API, contract clauses require the suppliers to have routines in place to map and prevent emissions of APIs to the environment. Although different in detail and how the information is applied (weighed in together with factors like price in Norway or as qualification/contract clauses in Sweden), both countries follow the logic of some level of disclosure of the supply chain and environmental strategies preventing emissions of APIs to the environment.

Stakeholder dialogues indicate that procurers in other countries, including Denmark, Germany and the Netherlands, are looking at these pioneers and investigate options to apply comparable methods.

From a variety of angles, the reports underpin the multitude of potential regulation, market requirements etc. to be applied, from the fundamental licence to operate based on environmental regulation, through market access (e.g. GMP), market incentives (public procurement) and voluntary initiatives.

4. National AMR Policies in India

National Action Plan

In 2017, India developed its National Action Plan on AMR in alignment with the WHO’s Global Action Plan for AMR (GAP-AMR).⁴⁵ The overarching goal of India’s National Action Plan on Antimicrobial Resistance (NAP-AMR) is to effectively combat antimicrobial resistance in India and contribute towards global efforts to tackle AMR. India seeks to establish and strengthen governance mechanisms as well as the capacity of all stakeholders to reduce the impact of AMR in the country.

The specific objectives of India’s NAP-AMR are:

1. Define strategic priorities, key actions, outputs, responsibilities, indicative timeline and budget to slow the emergence of AMR in India and strengthen organization and management structures to ensure intra- and inter-sectoral coordination with a One Health approach;
2. Combat AMR in India through better understanding and awareness of AMR, strengthened

surveillance, prevention of emergence and spread of resistant bacteria through infection prevention and control, optimized use of antibiotics in all sectors, and enhanced investments for AMR activities, research and innovations;

3. Enable monitoring and evaluation (M&E) of the NAP-AMR implementation based on the M&E framework.

Beyond the strategic priorities that follow the Global Action Plan (awareness and understanding, knowledge and evidence/surveillance, infection prevention and control, optimized use, investments in research and innovation), the Indian NAP specifically recommends the strengthening of India's leadership on AMR.

Although the general objectives allow room for interpretation, the strategic priorities set a clear focus on human and animal health and agriculture. The role of the environment is mentioned in the context of surveillance and indicated as a vector. Objective 3.5 is about Reducing environmental contamination with resistance genes, resistant pathogens and antimicrobial residues, including monitoring antibiotic residue and bacterial load, the need for removal of bacteria at treatment plants and environmental risk assessments. In this section, "factories" are mentioned as a source, but it is not explicit as to whether this means targeting the industry. Objective 2.3 about Surveillance of AMR is more specific, mentioning the development of a "national framework for surveillance of antibiotic residues and contaminants in environment including waste from farms, factories (pharmaceutical industry...)"

In line with this general direction, in March 2018 the Central Pollution Control Board (CPCB) of India under the Ministry of Environment, Forest and Climate Change, prepared draft standards for residual antibiotics in industrial effluents. The standards are based on predicted no effect values (PNEC) used to assess the concentration of antibiotics in water courses considered to be unlikely to increase the risk of resistance. The government has established an expert working group to evaluate the draft guidelines and has received inputs from industry. The guidelines are expected to be finalized shortly.

In recent years, the government has closed several manufacturing units for violating environmental standards, indicating the impact that more stringent regulation could have on the sector.¹⁹ Such regulation would make India the first country in the world to adopt specific maximum concentrations for pharmaceuticals. While it would be a regulative milestone, it also points in the direction of the challenges encountered with regard to monitoring and surveillance of AMR.

India's national AMR strategy is being implemented at the state level through the development and implemen-

tation of state action plans on AMR. At present only two states have developed such plans.

The Kerala Antimicrobial Resistance Strategic Action Plan

The state of Kerala became the first state to launch an action plan to contain AMR which was released on October 25th 2018.⁴⁶ The action plan aims to giving a strategic direction to the various activities undertaken to tackle antimicrobial resistance in the state. The action plan is truly 'one health' in its approach and was developed through a collaborative exercise facilitated through multi-stakeholder state level workshops on AMR. WHO has provided technical assistance to the state and helped facilitate the development of a multi-sectoral working group on AMR. However, as there is limited pharmaceutical activity in the state, the focus has been on addressing the other aspects of AMR.

Madhya Pradesh – second state to have plan for antimicrobial resistance

In July 2019, the Health Minister of Madhya Pradesh launched the second State Action Plan for Containment of Antimicrobial Resistance (MP-SAPCAR) in India.⁴⁷ The state's action plan also follows a 'one health' approach and multi-stakeholder collaboration to address the different aspects of AMR. While most of the focus remains on the medical use of antibiotics, there is also a raising awareness on the environment in the monitoring and evaluation framework. Under the infection prevention and control program, the number of pharmaceutical companies manufacturing antibiotics with effluent treatment plants will be evaluated. The number of licenses applied for and received by the state pollution control board will also be measured. These measures, if implemented, could provide a good starting point for developing mechanisms to reduce levels of antibiotic residues in the environment.

Other AMR Programs in India

India has begun to implement its national AMR action plan through engaging a wide range of government agencies and stakeholders. The National Centre for Disease Control (NCDC) is the nodal agency for AMR in the country. NCDC works closely with the Health Ministry, Department of Biotechnology and Indian Council for Medical Research (ICMR) to conduct various awareness and surveillance programs. For example, in 2013, ICMR initiated the Antimicrobial Resistance Surveillance and Research Network to understand the pattern and extent of AMR and use this evidence to guide strategies to control the spread of AMR.⁴⁸

At the state level, the Government of Kerala has been involved in creating awareness and developing skills for AMR containment among the medical community in Kerala. Awareness classes with focus on the importance of rational antibiotic use, infection control practices and need to follow institutional antibiotic policy have been held at all Government medical colleges in Kerala for faculty and students.

Most AMR interventions in the country tend to focus on human and animal health related activities led by various health, nutrition and veterinary institutes with the support of WHO and FAO. Recently, the government banned the sale and use of colistin, an antibiotic used to treat animals. International donors and NGOs support the 'one health' approach to AMR in India. Under this approach, some attention is being devoted to the environment. For example, a partnership between the Indian and Dutch governments is developing a pilot project in the state of Andhra Pradesh to implement an integrated approach to AMR that focuses on human, animal health, agriculture, sanitation and the environment. The project will adapt good practices and AMR expertise developed in the Netherlands to build the capacity of national and state level institutions.

Recently, state governments have begun to conduct workshops to sensitize local stakeholders on AMR in the environment. For example, the Punjab Pollution Control Board conducted a seminar for regulators and industry while the government of Kerala organized a joint workshop with Centre for Science and Environment and Centrient Pharmaceuticals on AMR in the environment.

A strategic partnership between the Department of Biotechnology (DBT), Government of India, and United Kingdom Research and Innovation (UKRI) commissioned a study to map the AMR research landscape in India. The study, conducted by the Centre for Disease Dynamics, Economics and Policy, indicated that AMR research studies in India were of limited scope in all areas, including humans, animals, environment, and others.¹⁵ The following recommendations were made with regards to tackling AMR in the environment:

- Studying the extent of environmental antibiotic pollution through pharmaceutical industrial waste (wastewater, solid waste and air) in various parts of India;
- Developing standards and detection tools for antibiotic residues in pharmaceutical industrial effluents;
- Examining acquisition of antibiotic-resistant bacteria during religious mass gatherings in rivers;
- Focusing on waste management to reduce the contamination of rivers during religious mass gatherings;
- Developing novel technologies to remove antibiotic-resistant bacteria and ARGs from sewage treatment plants (STPs) and hospital wastewater;

- Examining behavioural aspects of human waste disposal and its contribution to the problem of antibiotic resistance.

The study has catalysed funding for further research. The National Environmental Research Council in the UK (on behalf of the UKRI) and the Department of Biotechnology (DBT, Government of India) recently announced a joint call for collaborative research proposals focusing on AMR in the environment from antibiotic manufacturing waste.⁴⁹ A joint awareness raising workshop was held in New Delhi in May 2019 to sensitize AMR experts and research institutes in India and UK about the large grant program which provides funding to potential grantees in both countries from UKRI and DBT. Universities may conduct joint research on the following topics:

- Understanding the extent of antimicrobial pollution from antimicrobial manufacturing waste (wastewater, solid waste and atmospheric emissions), its pathways through environmental systems and the role in driving emergence and circulation of AMR in the environment;
- Development and validation of globally relevant standardised methods and tools for detection of active antimicrobials and resistant bacteria in effluents and receiving environments;
- Determining the impact on human and animal health from environmental exposure to high levels of antimicrobial pollution and resistant bacteria and genes.

While studying global best practices, Indian researchers are also developing innovative low-cost wastewater treatment technologies to reduce AMR. For example, the Tata Energy and Resources Institute (TERI), in collaboration with the University of Pannonia, Hungary, is on the verge of developing a simple treatment system to remediate pharmaceuticals from wastewater.⁵⁰

5. Shared objectives to achieve sustainably produced antibiotics

The current lack of enforceable global and national mechanisms to monitor and regulate antibiotic residues highlights the need for a shared vision of sustainable antibiotic manufacturing. While the overarching goal is to contribute to the fight against AMR and protecting human, animal and environmental health, the change needed is to **prevent emissions of antibiotics from manufacturing processes to the environment**. In practice, that means that solid and liquid waste must be contained and treated. Antibiotics should not leave the supply chain in any other form than formulated and packed medicine.

Most of the above-mentioned strategies, policies or voluntary commitments share the general objective of emission reductions, some of them with quantitative measures

based on risk assessments like PNEC or MIC. The next section will look more closely into the technical solutions for this, but for a holistic definition of sustainable manufacturing, more dimensions must be considered.

Although the UN Sustainable Development Goals do not mention AMR, they complement AMR strategies and the One Health Approach in providing guidance for sustainability in antibiotics manufacturing. As the world needs access to purposeful medication, including antibiotics, the pharmaceutical industry needs sustainable business models to deliver these. To enable this change, cost and resource efficiency of the technical implementation and the demand for sustainably produced antibiotics must go hand in hand. Public procurement is the area where the normative responsibility of governments and public interest go hand in hand with the needs of the supplying industry – as long as there is a willingness to reward or incentivize the more sustainable suppliers compared to other market players and the transparency is there to justify these incentives. Outdated technologies, poor waste management practices and, illegal dumping into the environment must end. It will only end if the market does not incentivize cost savings above all.

The case of India illustrates these dependencies: while being among the countries that are most exposed to AMR, India is also often called the pharmacy of the world. In 2016, the members of the SPHS Initiative alone procured USD 802 million worth of medical supplies and pharmaceuticals from Indian companies. The emissions from the industry contribute to the problem, while emerging changes and sustainability requirements in global procurement practices can become a risk for India's comparative advantage as the go to place for low priced drugs. This comes at a time when the local generic industry is already facing low profit margins and increasing competition and pricing pressures. Proactively contributing to emission reductions and showcasing good practices could be an opportunity for India to demonstrate leadership and commitment, being a pioneer in the fight against AMR as outlined in the NAP. Adopting sustainable antibiotic manufacturing practices and thereby setting global standards would be in the interest of the national economy, the global community as much as of the industry itself – meeting the expectations of stakeholders as well as shareholders.

While the pioneers in the procurement sphere start asking questions and require access to information, the most tangible methodology available has been proposed by the common antibiotics manufacturing framework by the AMR Industry Alliance. The framework sets out “minimum expectations for business policies, practices and behaviors to minimize the release of antibiotics into the environment from drug production and formulation. With a focus on effective waste management and control, the framework is designed to minimize conditions that may increase the development and spread of resistant bacteria.”⁵¹

“...sustainable antibiotics manufacturing reduces the release of antibiotics to the environment to levels that, according to best available knowledge, do not trigger antimicrobial resistance ”

Acknowledging the heavy regulation and certification needs to put the focus on end-of-pipe solutions. In the long run, this should also include effective systems to prevent or treat the waste earlier in the production process.

Balancing the goals of protecting the environment, reducing the spread of AMR and improving access to medicines by cost and resource efficient waste prevention and treatment requires a shared value approach through public private partnerships and collaboration between industry, governments and society. As in the case of India, national economy, global and local health, environment and the industry itself could profit from a holistic approach. Being proactive and visible provides the opportunity to join a growing group of pioneers, be part of defining new standards and attracting investments as much as customers. This requires leadership in government and industry and a solid engagement with other related stakeholders.

Similarly, the cost of not responding to this global challenge could be long term negative repercussions for local antibiotic manufacturers (beyond further promoting AMR). Several global pharmaceutical companies have begun to dismiss suppliers that do not follow good environmental practices. With changes in global procurement practices favouring sustainably manufactured antibiotics, local companies may no longer be competitive in terms of price and quality alone. Once governments introduce new limits and monitoring of antibiotic discharge levels (as announced in India), companies that fail to comply are likely to be fined, shut down or not have their licenses renewed. On the other hand, companies that do invest in sustainable antibiotic manufacturing and provide the necessary transparency would benefit from greater efficiency and increased competitiveness as well as reputational and marketing advantages differentiating them from their competitors.

In sum, **sustainable antibiotics manufacturing reduces the release of antibiotics to the environment to levels that, according to best available knowledge, do not trigger antimicrobial resistance.** To avoid trade-offs with resource and energy costs, this should be achieved in a cost and resource efficient way and supported by corresponding market demands. Cost cuts at the expense of health and environment are prevented by corporate responsibility in line with coherent regulation. This rewards pioneers and excludes the worst parts of the sector. In

accordance to the precautionary principle, the emissions should be as close to zero as possible and at least follow best available scientific advice.

These conclusions also build on round table discussions with Indian stakeholders from public and private sectors and civil society, hosted by SIWI Swedish Water House in Delhi, India in May 2019. A key conclusion was that the mere acknowledgement of shared objectives is an important achievement, reaching the fundamental point that antibiotics in the environment should be seen as hazardous and be regulated accordingly. Producing antibiotics sustainably will generate positive impacts on health, society, economy and the environment. This not only requires technical solutions to deactivate antibiotic molecules before they enter the environment, but also coherent support from regulation and procurement.

Some of the larger antibiotic manufacturers have adopted sustainable antibiotic manufacturing practices. However, scaling implementation globally requires understanding and meeting the reality of smaller companies like in the manufacturing clusters in India. There, the lack of awareness or knowledge and resources can be a barrier for improvements. Transitioning these small and medium enterprises towards sustainable antibiotic manufacturing may require technical and financial assistance to provide solutions to these challenges.

As an example, during World Water Week 2019,⁵² AMR Industry Alliance members GSK and Centrient Pharmaceuticals presented their work towards sustainable antibiotics manufacturing, highlighting the challenges with truly assessing the entire supply chain in line with the commitments as alliance members. GSK presented how compliance of manufacturing sites, both GSK owned and external suppliers, is assessed through audits, questionnaires and mass balance calculations of the environmental discharge concentrations. With the ambition of all sites being compliant by end of 2021, non-compliant sites will apply adequate measures or risk being exited by GSK. In line with this, Centrient Pharmaceuticals highlighted the need to use best available technologies with lowest possible environmental impact, dedicated wastewater treatment and antimicrobial activity testing to ensure that disposed water is clean. Technology remains the physical backbone of the solutions.

6. Technologies to reduce antibiotic emissions into the environment

While a definition of sustainable antibiotic manufacturing has been proposed in the previous section, there are no existing methodologies in place to achieve this. As seen in earlier sections of the paper, several global UN agencies and governments have

begun to advocate for the reduction of antibiotic emissions into the environment. Do we have the tools to achieve this?

Wastewater sources and flows in an antibiotic pharmaceutical manufacturing plant

In India, pharmaceutical industries (bulk drugs only) are classified as Grossly Polluting Industry (GPI) and are in most states in India required by state pollution control board laws to have effluent treatment plants (ETP) with zero liquid discharge (ZLD) facilities. Further, all the solid waste originating from the manufacturing unit is classified as hazardous waste as per the Hazardous and Other Waste Rules (2016).

The pharmaceutical industry produces a highly complex mixture of organic and inorganic compounds in the effluent stream, which requires treatment prior to discharge. Because of the complex nature of the wastewater, potent waste from pharmaceutical manufacturing are often difficult to break down using conventional wastewater treatment processes and often require a combination of different treatment processes across multiple treatment stages to make the wastewater fit for discharge into water bodies.

One of the critical measures for efficient management of the different waste streams is treatment at the source which would also allow for the potential recovery of certain compounds, thus reducing total environmental impact.

Depending on whether the antibiotic manufacturing process is chemical synthesis or fermentation, composition and quantity of the effluent can be different. Table 1 below summarizes the general waste streams, their broad characteristics and the commonly adopted handling processes.

Process Improvements for reducing antibiotic pollution in pharmaceutical effluent

Waste minimization at the point of source is always the preferred option when it comes to reducing antibiotics discharge during manufacturing. This is in line with the principles of the Common Antibiotic Manufacturing Framework developed by the AMR Industry Alliance. To achieve this, one must evaluate the complete manufacturing process and conduct a detailed mass balance to quantify the individual components in the process streams and develop a process strategy.

Improving resource and process efficiencies is essential and results in significant reduction of waste streams containing undesired compounds would require subsequent removal in the ETP for end-of-pipe treatment.

Type of Stream	Source within the manufacturing process	Typical treatment/management
Lean Streams • Low COD-Low TDS.	• Process waste from reactor washings • Wastewater from utilities including domestic wastewater, cooling tower blowdown, boiler blowdown etc.	Taken to Effluent Treatment Plant (ETP): → Primary Treatment . → Secondary Biological Treatment. → Tertiary treatment (filtration, Ultrafiltration and RO).
	• RO permeate.	→ RO permeate is recycled back in process, cooling tower, boiler makeup.
Mother Liquor Streams • High COD-High TDS. • High TDS-Low COD. • High COD-Low TDS.	• Process waste from reactor washings & product separation processes.	Taken to evaporator (multi-effect evaporator (MEE)) for concentration of the stream → Distillate from MEE is routed to ETP. → Recycled in utilities, when feasible.
	• Spent solvents from process plant comprising solvent reactions.	→ Solvent strippers for solvent recovery.
	• Waste streams from process plants with ammoniacal nitrogen reactions.	→ Taken to ammonia solvent stripper for removal of ammonia.

Table 1. Characterization of process waste streams.
 Abbreviations: COD – Chemical Oxygen Demand, TDS – Total Dissolved Solids, RO – Reverse Osmosis.

Examples of management and engineering responses for waste control and recovery of byproducts:

- Install stripping towers for solvent removal (recover solvents wherever possible);
- Conduct a program of sampling and testing solvents on wastewater flows;
- Collect and incinerate non-reusable combustible solvents and residues;
- Carefully schedule disposal of contaminated or spoiled fermentation batches;
- Eliminate all possible leakage of process materials;
- Avoid cross-contamination between clean and contaminated wastewaters;
- Collect and haul selected high organic wastes to land disposal or equivalent;
- Recycle seal waters on a vacuumed pump system;
- Improve housekeeping procedures.

Treatment technologies used for treatment of pharmaceutical wastewater

Given the diverse nature of wastewater from pharmaceuticals manufacturing, the treatment processes consequently vary to achieve minimal discharge of active ingredients to the environment. There is no single best technical solution since optimal effectiveness is specific for each compound and differs depending on the manufacturing process (synthetic or fermentation). As a pre-treatment, degrading the target contaminant

at the source point and recovering valuable by-products or unreacted raw materials in the waste stream should be prioritized for a good waste management strategy. This is then followed by using the appropriate treatment technologies in the effluent treatment stage that are not only cost-effective but also capable of deactivating the remaining target compounds (see table 2).

The treatment processes can be categorized into:

- Conventional wastewater treatment processes including a combination of physical (i.e. settling ponds), chemical (i.e. coagulation/flocculation) and biological processes (aerobic/anaerobic treatment);
- Tertiary and advanced treatment processes which may involve more advanced separation techniques such as membrane filtration, distillation, reverse osmosis, use of activated carbon, etc.;
- Advanced oxidation processes such as ozonation, Fenton oxidation, photocatalysis, plasma technology, ultrasonic technology, etc.;
- Combination technologies such as membrane bioreactors or use of synthetic biology such as enzymatic removal of active pharmaceutical ingredients.

In most pharmaceutical manufacturing plants in India, ETPs implementing Zero Liquid Discharge (ZLD) for wastewater treatment are designed and built using multiple treatment technologies. In line with current regulation, the existing effluent treatment plants are designed to meet the requirements for BOD, COD and TDS but there is no specific consideration with regards to API content. In order to control the discharge of active ingredients in the environment from the manufacturing process, new policies, guidelines and regulations are needed to address this parameter. With a ZLD system

Process Type	Treatment Technology	Impact
Physico-Chemical	Extensive holding and equalization of waste	Helps avoid operational problems by preventing sudden spikes in concentration & shock loading of treatment units
	Neutralization / pH adjustment	Ensure that the water is not too acidic or alkaline as well as to precipitate out dissolved ions and increase efficiency during biological treatment of the wastewater.
	Coagulation/Flocculation	Reduces pollutant load to downstream treatment processes by removing suspended and colloidal particles and impurities
Biological	Aerobic systems (most commonly activated sludge), anaerobic digestion, or anoxic process.	Efficient and economical technology to remove organic pollutants from the wastewater stream. Selection of the process depends on factors such as BOD levels, temperatures, presence of compounds that negatively affect the process.
Physical	Air stripping or steam stripping for removal of volatile organic solvents from wastewater.	Allows for the separation of solvents from the waste streams and potential recovery. Steam stripping has a more effective removal capability but, as a distillation process, is very energy intensive
	Advanced Filtration using either micro, ultra, nano filters, and reverse osmosis membranes.	Effective removal of particulate matter from the wastewater stream, which in more advanced systems retains ions and microorganisms.
	Evaporation technologies: Typical evaporation systems used in pharma industry: <ul style="list-style-type: none"> Falling film evaporator: low energy, used as a pre-concentrator in a MEE plant; Forced Circulation: Typically, best used for liquors that are susceptible to scaling or crystallizing, requires higher power and capital costs; Natural circulation: Used for reboiling in the evaporation process. Primarily used because of low power cost and ease of operation and ability of handling viscous materials; Plate type evaporator: shorter residence times and provides superior quality concentrates; MEE (Multi-effect evaporators): multi-staged evaporation process that provides a more thermally efficient evaporation process. 	Effective for removing salts or heavy metals from the wastewater stream that can be disposed of in hazardous waste management facilities. It can produce a high-quality condensate that can be recycled in the process, thereby allowing for a real zero liquid discharge.
Physical	Drying <ul style="list-style-type: none"> ATFD: Agitated Thin Film is ideal for continuous processing of concentrated materials to dry solids. 	Evaporation of water from highly viscous streams. The remaining dry solids (powder) has about 10-15% moisture content is considered hazardous and must be handled appropriately to avoid improper discharge into the environment.
Physical & Biological	Membrane Bio-reactor (MBR)	Offer advanced wastewater treatment and are generally more effective in the removal of particles and micro-organisms.
Oxidative	Ozone/Hydrogen Peroxide treatment	Treatment of recalcitrant organic contaminants by advanced oxidation processes.

Table 2. Treatment technologies and their applicability.

not initially designed to fully deactivate APIs in the waste streams, as well as lack of regular monitoring data, the effectiveness of the deployed treatment technologies to eliminate antibiotics is not fully established.

The diagram on page 17 represents the simplified process flow for an ETP using ZLD technology in many pharmaceutical manufacturing facilities in India.

A typical ETP with ZLD facilities implies that no liquids are discharged from manufacturing units. But this does not mean that no APIs reach the environment. While one could reason that since the manufacturing units are not discharging any liquid wastes there is no possibility of any discharge of antibiotics into the environment, there is no evidence to substantiate this conclusion. Apart from direct discharge of treated

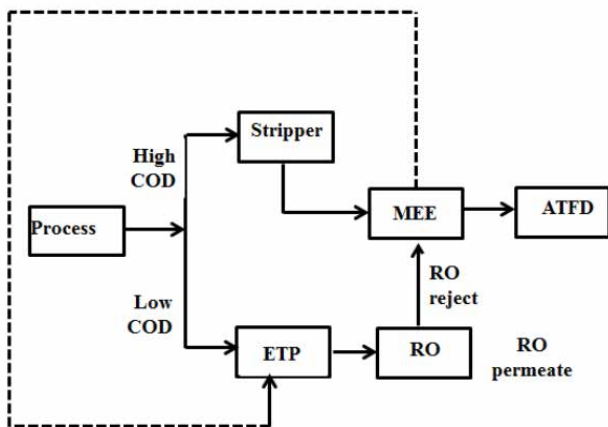

wastewater with active ingredients into the environment, there are other possible routes contributing to the problem. Some of these could be:

Discharge of API-rich wastewater during plant shutdowns

- Discharge of APIs into the environment through storm water drainage;
- Improper disposal of solid wastes into the environment;
- Re-use of treated wastewater within the premises of the manufacturing facilities for horticulture;
- Accidental spills of concentrated waste streams within the manufacturing facilities.

The treatment technologies used to prevent emissions of antibiotic and other pharmaceutical compounds into the environment from a pharmaceutical manufacturing

process can be broadly classified as physical, chemical or biological processes. There have been significant advances in technologies in each of these processes. Below please find a summary of various technologies and processes adopted in a typical pharmaceutical effluent treatment plant to control pollution.

There are several promising new emerging technologies including forward osmosis (FO), membrane distillation, irradiation processes, nanofiltration, advanced oxidation processes such as TiO_2 photocatalysis, Fenton reaction and ultrasonic irradiation. The Tata Energy and Resources Institute (TERI), in collaboration with The University of Pannonia, Hungary, is on the verge of developing a simple treatment system to remediate pharmaceuticals from wastewater⁵⁰. According to preliminary results, immobilisation and/or binding of enzymes to membranes can effectively break down/eliminate micro-pollutants. In this innovation, the bacterial enzymes embedded in the membrane reactor help degrade antibiotics.

These technologies have the potential to significantly improve the removal rate and biodegradability of pharmaceuticals from wastewater. However, most of these technologies have only been tested in laboratory or pilot scale with limited implementation. Industrial trials are required to improve treatment efficiencies, identify the degradation compounds and determine the

“Technology remains the physical backbone of the solutions.”



Photo:iStock

cost and feasibility of full-scale operations. Most of these physio-chemical processes remove most of the colloidal organic substances and suspended materials; however, refractory compounds remain in the water effluent and hence their applicability to different types of antibiotics are not well understood. There is a need to enhance the industry's understanding of the practical applicability of some of these new technical solutions before they can be considered potential options for effluent treatment plants. Energy requirements, maintenance costs and capital investments are considerations that need to be taken into account. An important tool to identify priorities is mass balance calculations, also promoted by the AMR Industry Alliance, as a model to easily account for potential losses of raw materials or products within the process flows.

Regardless of the end-of-pipe treatment technology chosen for a manufacturing facility, appropriate sampling and monitoring of final effluent streams within the facilities as well as receiving water bodies should be conducted regularly.

7. Monitoring Tools to Measure Antibiotic Pollution in Treated Wastewater & Water Samples

In order to both monitor the presence of antibiotics in the environment and to trace their impact on all components of One Health (environment, animal, and human health), it is fundamental to complement the measuring of the actual concentrations of APIs, with the genetic characterization of the microbial community. The presence of specific antimicrobial resistance genes (ARGs) could function as a proxy to evaluate and monitor the impact of antibiotic pollution in the environment, and help estimating further downstream effects such as impacts on human microbiota.

Presently in India, pharmaceutical wastewater streams, treated or untreated, are not regularly measured for API concentrations or ARGs. Apart from small scale and laboratory studies, there is little evidence of any systematic field level monitoring methods.

The most widely accepted way of determining the presence of pharmaceutical, including antibiotic, compounds is based on laboratory testing methods that involve physical separation and mass chromatography techniques. The USEPA Method 1694 which is based on this technique determines pharmaceuticals in environmental samples by high performance liquid chromatography combined with mass spectrometry (HPLC/MS/MS)⁵³. The primary benefit of this laboratory analytical method is that it can be used to detect even very low concentrations of different antibiotic compounds in samples. However, this process is very technical and requires significant expertise and cannot be efficiently done in field conditions.

“...it is fundamental to complement the measuring of the actual concentrations of APIs, with the genetic characterization of the microbial community.”

However, studying only the presence of antibiotics in the environment does not reveal the complete picture of AMR. It is important to study if antimicrobial resistance genes (ARGs) have been triggered, the abundance of the bacteria carrying the ARG/s, how fast they could be transmitted onto other non-resistant microbes and up the trophic chain.

Monitoring antimicrobial resistance genes in environmental matrices was recently recommended because there is increasing recognition that these genes can represent a key element to understanding AMR. Molecular analyses of environmental samples to identify the presence and diversity of resistance genes could potentially become very useful in identifying AMR hotspots.

Based on the available literature, there is no single best method to detect AMR or ARGs, and the methods vary in sensitivity, cost, and technical requirements. Table 3 summarizes the direct and indirect technologies and methods used to measure antibiotic concentration and antibiotic resistance in water samples.

8. Lack of Standardized Methods and Regulations for Monitoring Antimicrobial Manufacturing Wastes

Antibiotic manufacturers in India are currently not required to report discharge levels of APIs in wastewater, even though it is considered an important driver of AMR development and spread¹⁷. New regulations on levels of antibiotics in wastewater are emerging and manufacturing units will be required to measure antibiotic residues in their waste streams.

Depending on the production process, wastewater discharges have different characteristics (e.g. pH) and subsequent contaminants. The main chemicals in these effluents are solvents, detergents, disinfectants, and pharmaceutical products, all of which are potentially toxic to the environment. While pharmaceutical compounds can be detected using standard laboratory methods, there are no standard methods to analyse API residues or their transformation products that might form during wastewater treatment or in the environment after discharge. Neither do the established methodologies capture the risks associated with mixtures of different pollutants. Accordingly, the lack of standardized methods for API

Monitoring Method	Description along with advantages & disadvantages
Culture based method	<p>Microbial culture, where microorganisms are grown and counted in the laboratory, has historically been the gold-standard approach to detect antimicrobial-resistant pathogens.</p> <p>Culture based detection of AMR in environmental samples uses a variety of selective or screening media to isolate the bacteria of interest. Commercially available media exist that target a wide variety of bacteria. Equipment requirements are minimal, making this approach well suited to low resource settings.</p> <p>Culture-based approaches also have substantial limitations for environmental microbiology. In fact, most bacteria from the natural environment cannot be cultured in the laboratory, hence exclusively allowing <i>in situ</i> studies.</p>
Molecular Methods	<p>Molecular methods are used to genetically characterize microbial isolates (pathogens and commensals). They are used to detect and track ARGs and enumerate microbes (determine the number of individual viable microbes in a sample) from environmental samples.</p> <p>Modern molecular technologies and assays are robust, cost-effective, and easy to use. Conversely, earlier methodologies were expensive and complex, which have limited the widespread use in this field</p>
Metagenomics	<p>In classic metagenomics, total DNA extracted from an environmental sample is sequenced extensively. Resistance genes in that environmental sample can then be identified based on sequence similarity to known ARGs.</p> <p>The main benefit of metagenomic methods is the ability to detect many different resistance and non-resistance genes present in a sample in a single metagenomic-sequencing run.</p> <p>There are several limitations for this method. Metagenomics methods are quite expensive, and quantification is limited to proportions rather than absolute numbers of resistant organisms. Sensitivity can be limited and may vary significantly, because reads for specific genes are only a small proportion of the total number of reads.</p>
Functional Genomics	<p>Functional genomic approaches can identify novel ARGs, unlike metagenomic strategies. Functional genomic approaches have been used to identify novel genes in a wide variety of environments. While functional genomics is a powerful tool for identifying new ARGs, it is not likely to be useful in general surveillance.</p>
Whole Genome Sequencing (WGS)	<p>It is sometimes necessary to track a resistant pathogen, or a resistance gene, to a specific source, such as a hospital or a farm. Such epidemiological investigations require methods with a high degree of resolution, meaning the ability to distinguish between closely related genes or pathogens.</p> <p>Via WGS of bacterial isolates, the entire genome of each organism is sequenced, so WGS represents the upper limit for detecting variation. Even in pathogens with little overall diversity, isolates can be grouped based on a few shared sequence variants, making this a powerful epidemiological approach. WGS is used regularly in epidemiological investigations of foodborne pathogens in North America and Europe.</p> <p>In some situations, technical or financial considerations might prevent WGS from being used.</p>

Table 3. Screening procedures for resistance genes.

analysis in the environment also applies for assessing the risks with manufacturing waste.

The concentrations of antimicrobials in surface waters receiving discharges from pharmaceutical manufacturing effluents are typically found at low concentrations (below µg/L levels), and therefore require extensive sample preparation and concentration. However, a major limitation of the current analytical approaches is that they are constrained to analyse a few well-known target analytes. This means that potential transformation products formed during treatment or disposal in the environment are not considered. This is one of the reasons why it is important to monitor both API and API transformation products in manufacturing wastes.

Due to the nature and low volatility of antimicrobials, analysing these compounds in environmental and biological samples is commonly done in controlled laboratory conditions using liquid chromatography (LC) coupled with mass spectrometry (LC-MS) detection. However, dependence on laboratory-based analysis will not be sufficient to enable the operators of effluent treatment plants and regulators to monitor the performance of ETPs in treating antibiotics in field conditions.

Advances in instrumentation have resulted in faster and more selective analysis of multiple antimicrobial classes in water samples using ultra-high-pressure LC coupled with hybrid quadrupole-linear ion trap MS detection systems. The LC-MS methods are very sensitive, with



Photo : iStock

method quantification limits reaching sub-ppt levels (1–100 ng/L), depending on the type of antimicrobials and the complexity of the sample matrices.

Recently, an increasing number of publications reported using high-resolution MS for environmental monitoring to move away from target-driven analysis. Liquid chromatography coupled with high-resolution MS, allow for target analysis to be done alongside non-target screening.

The ability of new advancements in MS instruments to acquire full mass range spectra without sacrificing speed or sensitivity makes these some of these new types of instruments an excellent choice for qualitative and quantitative analyses across a wide range of antimicrobial classes in the presence of complex matrices. However, considering the costs associated with such high-resolution MS platform, their applicability is limited to few laboratories.

Need for Complementary Bioanalytical and Molecular Assays to Assess Impacts of Manufacturing Wastes

Environmental issues require a comprehensive environmental evaluation through combined bioanalytical approaches with exposure and hazard analysis. In the context of AMR, this would require combining MS (targeted vs screening/retrospective) focused on chemical targets with bioanalytical approaches focused on the selective effect, i.e. measuring phenotypic resistance or the increase in resistance genes. In addition, eco-toxicity tests should be implemented as part of the standard test, using whole organisms (fish assays), bacteria, or cell toxicity assays.

While the above sections reveal several technologies are available for monitoring antibiotic residues in pharmaceutical waste, several challenges and gaps remain in their applicability and commercial viability. These include the need to determine the effectiveness of ZLD as a process technology to control AMR in the environment. Is ZLD the best option for API and formulation manufacturers? It is important for these manufacturing units to first focus on reducing and segregating wastes from the manufacturing processes and then think about treatment options. As discussed, there are various treatment technologies but their applicability and effectiveness of treatment of specific antibiotics is not well known. It is important to invest in R&D to determine this. Furthermore, monitoring should include both testing for residual antibiotics as well as antibiotic-resistance genes or resistant microbes. Monitoring should also look at intermediate antibiotic products as a potential contributor to AMR.

Today, monitoring technologies are limited and mostly lab scale based and not fully standardized. It is important to standardize the monitoring techniques and identify technologies that can be cost-effectively applied in field conditions.

Conclusions

Antibiotics in the environment increase the risk of promoting antimicrobial resistance. In addition, its presence in water bodies may not be directly harmful to humans, but the effects on organisms susceptible to it could affect the food web which, in turn, will affect the health and livelihood of the surrounding population. Preventing this unwanted pollutant from reaching water bodies will not only improve water quality but also secure a clean resource for the pharmaceutical companies. With depleting water levels, it is even more necessary to evaluate the bigger picture and focus on improving the efficiency of using this resource.

To prevent the manufacturing process of antibiotics from contributing to this risk, APIs need to be retained in the production facility or deactivated before liquid or solid waste streams can enter the environment. Acknowledging this fundamental requirement as a shared objective in a broad stakeholder dialogue has been the main outcome of the project REAP. There are technical solutions available to ensure the necessary waste treatment, and there is a growing interest from regulators and procurers to demand, but also incentivize such improvements. The largest challenge is the access to verified information about real improvements made, to motivate these incentives, but also to find more holistic and resource centred approaches that address the whole manufacturing process rather than only the waste and effluent streams. In addition, the technical solutions can be cost- and energy-intensive, which makes incentives and a regulative level-playing field important factors to prevent trade-offs between environmental and economic objectives.

These findings are in line with a recent analysis done by Swedish researchers, highlighting “the complexity of the relations between different types of actors, their inter-national dependency and the need for transparency”.⁵⁴ In particular, the purchasing power in high income countries and multinational cooperation are described as the leverage needed to initiate change.

If releasing antibiotics to the environment from manufacturing waste streams so obviously adds mutual risks for all stakeholders involved – including global health and business risks, why does change seem so difficult to achieve? How can a more sustainable practice become a no-regret option for all stakeholders involved in antibiotics manufacturing, regulation and purchasing?

While historically, the lack of awareness might have been part of the problem, the key counterincentives today are the lack of a true market demand paired with the lack of collaboration to jointly define clear objectives and access to verified information about physical progress made. Considering that it is possible to get away with pollution because the market primarily rewards

the cheapest possible production without addressing sustainability challenges, even voluntary initiatives are counteracted. But it is also hard to promote better practice if the few attempts to improve the situation do not get access to the data that shows what the production really looks like.

Many of the existing strategies, policies or voluntary commitments share general objectives with regards to reduced emissions of antibiotics from manufacturing. Industry initiatives, procurement efforts and some first regulative attempts, together with a growing public concern demonstrate the growing maturity of how the risk is being perceived from the local to the global level. But the mutual dependencies are barely addressed.

While the project REAP has contributed to broadening the consensus about the general objectives for addressing this challenge, the urgently needed resource and cost-efficient solutions, together with coherent regulation and market incentives require transparency and accountability from all sides.

Importantly, there is limited scientific evidence for what discharge levels are to be considered safe. The required solutions can be costly and energy intensive. Regulation of the sector is complex and the established quality requirements and compliance control systems do not include environmental dimensions but are also inflexible with regard to integrating additional factors.

The linkage between environmental and health concerns also means that different government entities need to collaborate: While the impacts of pharmaceutical pollution and the aquatic environment as a vector usually lie under the responsibility of ministries for the environment and their agencies, the upstream regulation on both use and manufacturing are the realm of health ministries and possibly industrial regulators. Accordingly, strategies around pharmaceuticals in the environment were early in highlighting all the relevant sources, including manufacturing waste or effluents, while the upstream regulation is lagging behind. For example Sweden’s Ministry for Environment and the Environmental Protection Agency are proactive in deploying advanced wastewater treatment. But considering how pharmaceuticals are being manufactured, one finds only the procurers that are trying to use their operating space to impose sustainability criteria. The largest market segment, falling under a generic substitution scheme for prescription drugs, is only directed by the lowest possible price.

The expected regulation of maximum concentrations for APIs in industrial effluents in India would be a global milestone, setting the precedence for a regulative baseline. This way of cutting off, or disincentivizing

the worst practice, should be complemented by more advanced procurement requirements that would provide the positive incentives for the pioneers in the sector. A model of sticks and carrots.

Monitoring and surveillance in line with improved access to relevant data and improved risk assessment are key factors, where research, engineering, purchasers and regulators need to collaborate and learn. Improving the mutual understanding, through piloting and learning

from innovative solutions, there will be standards needed in the long run, defining both baseline requirements and best available practice.

This would not only enable the supply and demand side to improve compliance with their own and mutual commitments, but it would also significantly reduce the burden of audits and site visits that the industry is confronted with, given the current lack of standards, trust and transparency.



Photo : iStock

Recommendations

Reducing Emissions from Antibiotics Production requires all stakeholders to transparently live up to the already existing commitments and mutually supported objectives to enable better regulation and incentives. The following recommendations outline key factors to coherently enable a more sustainable practice in antibiotics manufacturing. For all levels, the collaboration between public and private stakeholders and the inclusion of independent experts and scientists as well as civil society is essential to ensure that solutions are holistic, fit for purpose and mutually accepted.

- **National and state level AMR strategies and action plans should address antibiotic discharge into the environment from manufacturing**, in addition to the current focus on the human, animal, agricultural and WASH dimensions of AMR. A special section on addressing the environmental aspects of antibiotic manufacturing should be included into existing AMR policies and the design of new programs.
- **Policy coherence is required between ministries of environment**, health and industry in addressing the environmental pollution caused by untreated antibiotic waste. While the impacts are in the realm of industry and environment ministries, much of the required upstream regulation and the topic of AMR itself is in the responsibility of health departments. A political One Health Approach needs to link these responsibilities.
- **Regulation should limit antibiotic discharge into the environment**. National level regulatory standards on AMR pollution as being developed by the Indian Central Pollution Control Board are a step in the right direction. Standards such as Predicted No Effect Concentrations should be developed in consultation with industry, scientists and other stakeholders to ensure that the directives are fit for purpose and achievable. This also requires enforcement mechanisms including fines, withdrawal of licences or, ultimately, closing of sites in case of continuous violations.
- **Public procurement should promote sustainable manufacturing**. As currently being developed or already applied by a few procurers worldwide, sustainability criteria can be applied either for prequalification, as contract clauses or weighed in as evaluation criteria, complementing the sole focus on the lowest available price. High income countries have a special responsibility, scaling to global and coherent implementation is important for efficiency and changing the definition of competitiveness.
- **Suppliers should contribute to transparency and the collaborative promotion of solutions**. The physical change will take place in the supply chain. But addressing their own supply chains, companies might be in a similar situation like procurers, trying to find and verify information. The industry can profit from sharing experience with technical solutions to improve harmonization and even impact future regulation or market requirements. To enable this, access to information about the supply chain and emission data must be available to other relevant stakeholders. This will also help to communicate the complexity of the supply chain and the challenges for implementing solutions.
- **Multiple funding sources and incentive systems are needed to achieve large scale improvements**. While direct market incentives, e.g. through sustainable public procurement, can provide a certain level of incentives, this will not be enough to trigger the required, major, investments in production and waste management facilities. Although politically perhaps difficult to achieve, a dedicated international fund for innovation and sustainability in antibiotics manufacturing would have a strong impact. It should be complemented by low interest loans provided by the financial sector, in line with their own sustainability strategies and criticism of the industry. Especially SMEs will have difficulties in accessing major international funds and lack the financial reserves for larger investments. Here, funds and tax reliefs on national level should be developed as a tool for governments to trigger change in the domestic industry, in the interest of sustainability as much as competitiveness.
- **Effective monitoring systems are needed as the baseline for compliance control**. Understanding the sources and environmental prevalence of antibiotics as well as resistance genes, requires regular monitoring at the relevant effluent sources (be it at the factory, CETPs or the final destination of solid wastes) as well as in the recipient waterbodies. This implies investments in new technologies and information management systems to record, track and monitor pollution. In the surveillance, independence is a crucial factor that could be achieved by involvement of universities or research institutes.
- **Effective enforcement requires acceptance, training and capacity building in the industry, international or government agencies and local communities**. To improve transparency and prevent potential conflicts of interest, close collaboration is necessary between public and private stakeholders, including civil society and NGOs. The existing training capacities in the industry are an important resource to build both trust and competence, if opened for broader stakeholder engagement.

- **Transparency and confidentiality may be conflicting interests that have to be addressed.** Process data and environmental information is necessary to incentivize desired practice and disincentivize other. But the competitiveness of the market makes it necessary to find a balance that on the one hand provides access to the adequate level of information that the relevant stakeholders need to fulfil their roles and responsibilities, but on the other hand prevents misuse of data or undue advantages for competitors.
- **Standardization and sharing of best practices should contribute to coherent implementation and replication of solutions.** Based on the experiences made by the pioneers today, future international standards should ensure that manufacturing discharges do not contribute to the promotion of AMR. This should become the shared baseline for manufacturing operations and market access. New international mechanisms (agreements and/

or agencies) are needed to supervise harmonization, implementation and monitoring in line with these standards. From the baseline requirements to the frontrunner level, once better standards are established, they should be communicated through labelling or other adequate systems. Even here, civil society, NGOs and scientists must be included in the development of standards to ensure that varying interests are represented.

Achieving this, requires a **multi stakeholder and public-private partnership**, addressing the given complexity of manufacturing, local and global impacts, market and regulation in a collaborative and transparent way. Experience needs to be built and shared for best practice in manufacturing as much as in providing incentives. To provide space for this kind of trust building and mutual learning and jointly evolving and implementing the above recommendation, a **long-term global collaboration platform** is needed.

“...the collaboration between public and private stakeholders and the inclusion of independent experts and scientists as well as civil society is essential to ensure that solutions are holistic, fit for purpose and mutually accepted.”



Photo : iStock

References

1. World Health Organization, “Tuberculosis (TB)”, webpage, <https://www.who.int/tb/en/>, accessed 2019/1/9.
2. O’Neill J., 2016. Tackling drug-resistant infections globally: final report and recommendations. *AMR Review*. https://amr-review.org/sites/default/files/160525_Final%20paper_with%20cover.pdf, accessed 2019/1/8.
3. UNEP, 2017. Frontiers 2017 Emerging Issues of Environmental Concern. United Nations Environment Programme, Nairobi. https://wedocs.unep.org/bitstream/handle/20.500.11822/22255/Frontiers_2017_EN.pdf
4. Baquero F., Martínez J.L., and Cantón R., 2008. Antibiotics and antibiotic resistance in water environments. *COBIOT*, 19(3): 260–265.
5. Lupo A., Coyne S., and Berendonk T.U., 2012. Origin and evolution of antibiotic resistance: the common mechanisms of emergence and spread in water bodies. *Front Microbiol*, 3:18.
6. Cabello F.C., Godfrey H.P., Tomova A., Ivanova L., Dölz H., Millanao A., et al., 2013. Antimicrobial use in aquaculture re-examined: its relevance to antimicrobial resistance and to animal and human health. *Environ Microbiol*, 15: 1917–1942.
7. Santos L., and Ramos F., 2018. Antimicrobial resistance in aquaculture: current knowledge and alternatives to tackle the problem. *Int. J. Antimicrob. Agents*, 52(2): 135–143.
8. European Chemicals Bureau, 2003. Technical Guidance Document on Risk Assessment. European Communities. https://echa.europa.eu/documents/10162/16960216/tgdpart2_2ed_en.pdf
9. Andrews J.M., 2001. Determination of minimum inhibitory concentrations. *J Antimicrob Chemother*, 48 (1): 5–16. doi: 10.1093/jac/48.suppl_1.5.
10. Boxall A. and Wilkinson J., 2019. Identifying hotspots of resistance selection from antibiotic exposure in urban environments around the world. SETAC Europe 29th Annual Meeting, Helsinki, May 27, 2019.
11. Wilke C., 2019. Many of the world’s rivers are flush with dangerous levels of antibiotics. *ScienceNews*. <https://www.sciencenews.org/article/world-rivers-dangerous-levels-antibiotics> accessed at 2020-01-10.
12. UK Government 2019, Tackling antimicrobial resistance 2019–2024. https://assets.publishing.service.gov.uk/government/uploads/system/uploads/attachment_data/file/784894/UK_AMR_5_year_national_action_plan.pdf
13. OECD, 2019, Pharmaceutical Residues in Freshwater: Hazards and Policy Responses, *OECD Studies on Water*, OECD Publishing, Paris. <https://doi.org/10.1787/c936f42d-en>
14. SAICM, 2015. Report of the International Conference on Chemicals Management on the work of its fourth session (SAICM/ICCM.4/15). http://www.saicm.org/Portals/12/documents/meetings/ICCM4/doc/K1606013_e.pdf
15. Gandra S., Joshi J., Trett A., Lamkang A.S., and Laxminarayan R., 2017. Scoping Report on Antimicrobial Resistance in India. Washington, DC: Center for Disease Dynamics, Economics & Policy., <https://cddep.org/wp-content/uploads/2017/11/AMR-INDIA-SCOPING-REPORT.pdf>, accessed 2019/1/8. See further original papers referenced there.
16. Skariyachan S., Mahajanakatti A.B., Grandhi N.J., Prasanna A., Sen B., Sharma N., et al., 2015. Environmental monitoring of bacterial contamination and antibiotic resistance patterns of the fecal coliforms isolated from Cauvery River, a major drinking water source in Karnataka, India. *Environ Monit Assess*, 187(5): 279.
17. Larsson D.G.J., de Pedro C, and Paxeus N. 2007. Effluent from drug manufactures contains extremely high levels of pharmaceuticals. *J Haz Mat*. 148 (3), 751-755
18. Gothwal R., and Shashidhar T., 2017. Proliferation of Ciprofloxacin Resistant Bacteria in Polluted Sediments of Musi River, India. *Soil Sediment Contam*, 26(5), 501-509.
19. Hyderabad’s pharmaceutical pollution crisis, Nordea and Changing Markets Foundation, January 2018.
20. DownToEarth Staff, 2018. India’s antibiotics consumption shot up by 103% since 2000: study. *DownToEarth*. <https://www.downtoearth.org.in/news/health/india-s-antibiotics-consumption-shot-by-103-since-2000-study-60037>
21. Rama Rao K.T. (Telangana Minister of Industries & Commerce), 2018. Telangana to set up hub for biotech, pharma sector. <https://www.thehindubusinessline.com/news/telangana-to-set-up-hub-for-biotech-pharma-sector/article24565959.ece#> for biotech, pharma sector. <https://www.thehindubusinessline.com/news/telangana-to-set-up-hub-for-biotech-pharma-sector/article24565959.ece#>
22. Dayananda S., 2017. Comparative Evaluation of Drug Resistance Among Culturable Bacteria isolated from Pharmaceutical Manufacturing Clusters (PMC) in and around Hyderabad. <http://bdmai.org/wp-content/uploads/2017/05/BDMA-26-4-17.pdf>
23. World Health Organization, 2015. *Global Action Plan on Antimicrobial Resistance*, <https://www.who.int/antimicrobial-resistance/publications/global-action-plan/en/>, accessed 2019/1/8.
24. Wellcome Trust, US Centers for Disease Control & Prevention, and UK Science & Innovation Network, 2018. *Initiatives for Addressing Antimicrobial Resistance in the Environment, Current Situation and Challenges*, accessed 2019/1/15.
25. AMR Industry Alliance. <https://www.amrindustryalliance.org/amr-industry-alliance-declaration/>
26. IFPMA: Policy Action: https://www.ifpma.org/wp-content/uploads/2018/09/IFPMA_AMR_Position_Incentives_Overarching_2018.pdf
27. IFPMA: Policy Action: https://www.ifpma.org/wp-content/uploads/2018/09/IFPMA_AMR_Position_Incentives_Pull_2018.pdf

28. AMR Industry Alliance. <https://www.amrindustryalliance.org/industry-roadmap-for-progress-on-combatting-antimicrobial-resistance/>
29. AMR Industry Alliance, 2018. *Common Antibiotic Manufacturing Framework*, https://www.amrindustryalliance.org/wp-content/uploads/2018/02/AMR_Industry_Alliance_Manufacturing_Framework.pdf, accessed 2019/1/8.
30. AMR Industry Alliance, 2020. AMR Industry Alliance 2020 Progress Report. <https://www.amrindustryalliance.org/wp-content/uploads/2020/01/AMR-Industry-Alliance-2020-Progress-Report-publication-1.pdf>
31. IACG, 2019. No Time to Wait: Securing the future from drug-resistant infections https://www.who.int/antimicrobial-resistance/interagency-coordination-group/IACG_final_report_EN.pdf?ua=1
32. European Commission. https://ec.europa.eu/health/amr/action_eu_en
33. EP resolution P8_TA(2018)0354 http://www.europarl.europa.eu/doceo/document/TA-8-2018-0354_EN.pdf
34. World Bank 2017, Drug resistant infections – a threat to our economic future. <http://documents.worldbank.org/curated/en/323311493396993758/pdf/final-report.pdf>
35. WHO 2019, working document QAS/19-802, https://www.who.int/medicines/areas/quality_safety/quality_assurance/qas19_802_environmental_aspects_of_GMP.pdf
36. Access to Medicine Foundation: Antimicrobial Resistance Benchmark 2018 https://www.accessmedicineindex.org/media/uploads/downloads/5bc5edd8367eb_Antimicrobial-Resistance-Benchmark-2018.pdf
37. Access to Medicine Foundation: Antimicrobial Resistance Benchmark 2020 https://accessmedicinefoundation.org/media/uploads/downloads/5e270aa36821a_Antimicrobial_Resistance_Benchmark_2020.pdf
38. Salazar Cota A., Fernández L., and Dalaison W., 2018. How to encourage green procurement in IDB funded projects? Inter-American Development Bank. <https://publications.iadb.org/publications/english/document/Green-Procurement-How-to-Encourage-Green-Procurement-Practices-in-IDB-Funded-Projects.pdf>
39. World Bank, 2019. An introduction for practitioners to sustainable procurement in World Bank IPF projects. <http://pubdocs.worldbank.org/en/788731479395390605/Guidance-on-Sustainable-Procurement.pdf>
40. Lonnaeus K., 2016. Sustainable pharmaceuticals – public procurement as a political tool. SIWI. <http://www.swedishwaterhouse.se/wp-content/uploads/Partner-publication-Sustainable-Pharmaceuticals-web.pdf>
41. SPHS <https://savinglivesustainably.org/who-we-are.html>
42. Sustainable Health in Procurement Project <https://savinglivesustainably.org/knowledge-practice/contribution/sustainable-health-in-procurement-project-shipp/Kp777B.html>
43. Sykehusinnkjøp HF, 2019. New environmental criteria for the procurement of pharmaceuticals <https://sykehusinnkjop.no/nyheter/new-environmental-criteria-for-the-procurement-of-pharmaceuticals>
44. Swedish National Agency for Public Procurement (In Swedish), 2019: <https://www.upphandlingsmyndigheten.se/>
45. Government of India. National Action Plan on Antimicrobial Resistance, 2017. <https://ncdc.gov.in/WriteReadData/linkimages/AMR/File645.pdf>
46. Government of Kerala. Kerala antimicrobial resistance strategic action plan: One Health Response to AMR Containment.
47. Madhya Pradesh State Action Plan for Containment of Antimicrobial Resistance, Government of Madhya Pradesh, July 2019.
48. Walia K., Madhumathi J., Veeraraghavan B., Chakrabarti A., Kapil A., Ray P., et al., 2019. Establishing Antimicrobial Resistance Surveillance & Research Network in India: Journey so far. *IJMR*, 149(2): 164.
49. Wickens V., 2019. UK-India tackling AMR in the environment from antimicrobial manufacturing waste – Partnership workshop. <https://nerc.ukri.org/research/funded/programmes/amr/news/ukindia-workshop/>
50. Nanthakumar K., 2019. The Energy and Resources Institute. Drying up antimicrobial resistance with innovative wastewater treatment. <https://www.teriin.org/blog/drying-antimicrobial-resistance-innovative-wastewater-treatment>
51. AMR Industry Alliance, 2019: Making Antibiotics Responsibly https://www.amrindustryalliance.org/wp-content/uploads/2019/11/Making-antibiotics-responsibly_A-common-manufacturing-framework-to-tackle-AMR.pdf
52. World Water Week ,2019. *Reducing Emissions from Antibiotics Production: Supply and Demand side Collaborations* <https://www.worldwaterweek.org/event/8672-reducing-emissions-from-antibiotics-production-supply-and-demand-side-collaboration>
53. U.S. Environmental Protection Agency, 2007. Method 1694: Pharmaceuticals and Personal Care Products in Water, Soil, Sediment, and Biosolids by HPLC/MS/MS. https://www.epa.gov/sites/production/files/2015-10/documents/method_1694_2007.pdf (accessed 2020/1/20).
54. Nijssingh N., Munthe C., and Larsson D.J., 2019. Managing pollution from antibiotics manufacturing: charting actors, incentives and disincentives. *Environ Health* 18(1): 95. <https://doi.org/10.1186/s12940-019-0531-1>

About this publication

This whitepaper summarizes the findings of the project Reducing Emissions from Antibiotics Production (REAP), that SIWI has run in partnership with UNDP, funded by the Swedish Postcode Foundation. It is written together with Shawview Consulting and analyses policies and strategies against antimicrobial resistance (AMR). This also includes practical solutions to address emissions of antibiotics from manufacturing sites and the enabling factors required to implement these solutions.

A key result of the project is the acknowledgement of one essential shared objective for responsible manufacturing of antibiotics by pioneering stakeholders in the industry, public procurement and regulation: to reduce emissions of antibiotics to the environment to a level that prevents the promotion of AMR. There are technical solutions available to ensure the necessary waste treatment, and there is a growing interest from regulators and procurers to demand, but also incentivize such improvements. Multi-stakeholder collaboration is required to address the mutual dependency between incentives for more sustainable industry practice and the access to information about real improvements made.